

UM Topload Washer Extractor Model

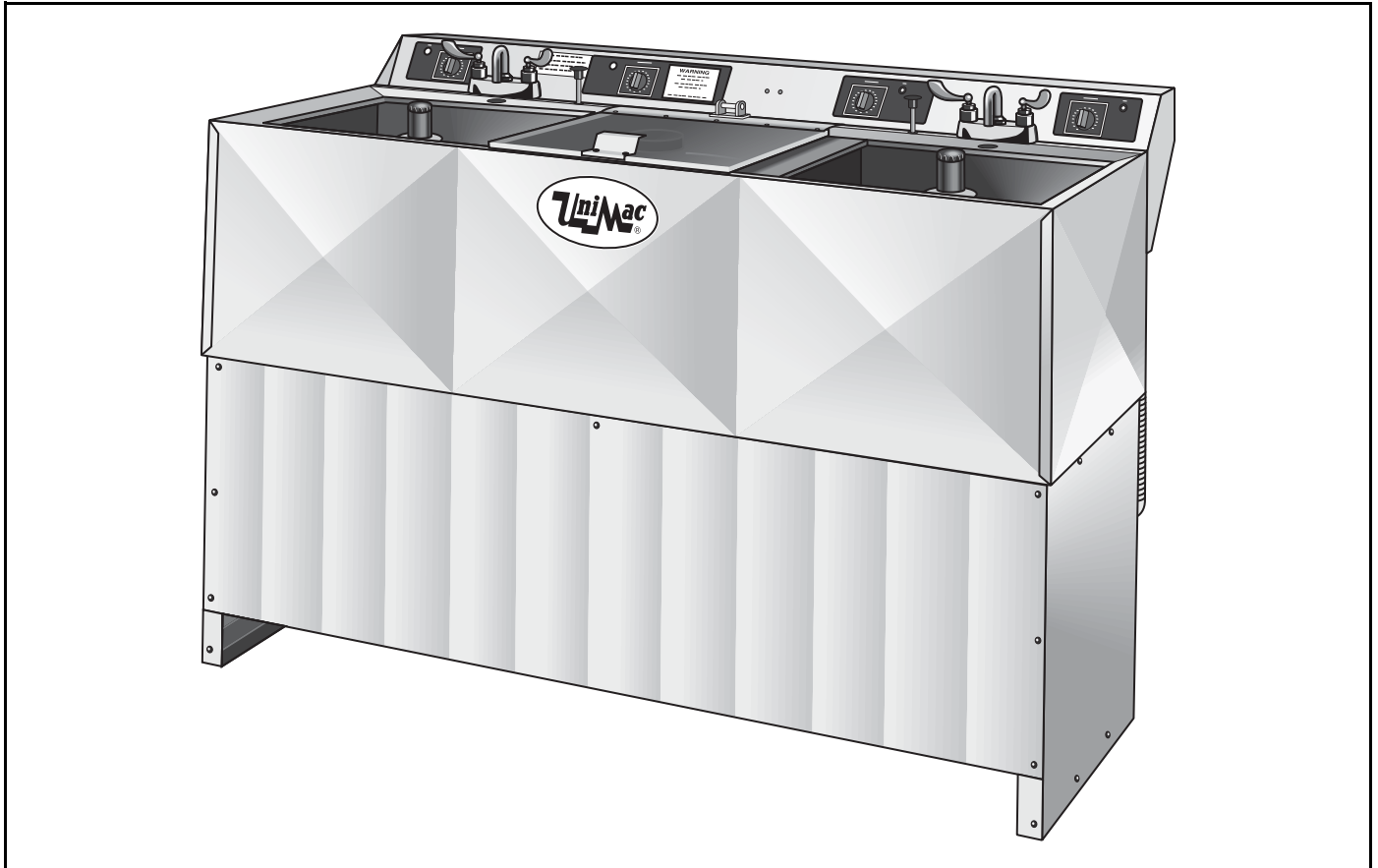

Model UM202 Specs

APPLICATION:

Industry leading G-force for “best in industry” water extraction. When primary soiled goods are terry towels.

EXAMPLES:

Carwash, Restaurant and Health Club

Specifications for Model UM202 Washer-Extractor

- 1. CAPACITY:** Shall be capable of washing, rinsing and extracting up to 150 pounds (68 kg) (dry weight) of washables per hour. This equipment shall be a 36 pound (16 kg) unit consisting of a combination of two (2) washing compartments and one (1) rinse-extractor compartment, each washing compartment capable of processing a 12 pound (5.4 kg) (dry weight) load and the rinse-extractor a 12 pound (5.4 kg) load. All three compartments shall be capable of working simultaneously and independently.
- 2. CONSTRUCTION AND MATERIALS:** The compartments, front panel skirt and control panel housing shall be 20-gauge type 304 stainless steel. The chassis ends shall be constructed of 1/8 inch (3.2 mm) angle iron and enclosed with stainless steel. All top surface joints shall be heliarc welded. All other joints shall be electric spot welded and soldered. The rinse-extractor cover shall be made of transparent lexan and include a water deflector dome to prevent damage to fabrics. The center plates for the transmissions shall be made of 304 stainless steel. The basket ball shall be nylon, hex shaped around sides to eliminate necessity for pins in basket. The agitator shall be made of heat resistant polypropylene and cast in permanent type mold to maintain a weight of less than 4 pounds (1.8 kg) to prevent excessive wear of splines and transmission gear.
- 3. ELECTRICAL REQUIREMENTS AND MOTORS:** Each washing compartment agitator shall be independently operated by one 1/3 HP motor. The rinse-extractor shall be driven by a direct drive 1 HP motor. The extractor motor shall be totally enclosed to resist moisture and vertically mounted in rubber to eliminate vibration. It shall operate at a speed of 1580 RPM and produce "G" Forces of 678 G's to ensure positive and thorough rinsing and maximum extraction.

The voltage of the agitator motors and all controls is 115 Volt. The extractor motor shall be 3 Phase and utilize an automatic reversing action of the motor to achieve a rapid deceleration to stop without using a friction type brake. Circuit breaker requirements shall be 15 Amps. Each motor shall be protected with internal thermal protection mounted in the individual motors. All exposed wiring shall be enclosed in flexible metal conduit.
- 4. PLUMBING:** All water supply plumbing shall be either copper or brass. Two (2) 3/4 inch (19 mm) cold and one (1) 3/4 inch hot inlets shall be provided. Three heavy duty rubber hose tested for 150 psi (10.3 bar) shall be provided. Drain valve shall be quick opening type requiring no packing glands, with neoprene rubber valve discs. Drain lines for washing compartments and rinse-extractor compartment shall be connected into one (1) manifold. The manifold shall be supplied with a 2 inch (51 mm) flexible drain hose.

The rinse-extractor compartment shall be provided with two (2) spray nozzles and a hemispherical spray deflector to divert the spray rinse water into the fabric in the extractor basket while the basket is spinning. The electric water valve supplying this water shall be at least 1/2 inch (12.7 mm) full ported.
- 5. SAFETY FEATURES:** The rinse-extractor compartment shall be provided with a cover lid which will be locked closed while the basket is in motion. An electronic motion detector shall be used to detect rotation of the basket and prevent opening of the lid while basket is in motion. Also, the motor and rinse solenoid cannot be energized with the lid in open position. These shall be of fail safe design so that in case of power failure or other failure the lid cannot be opened while the basket is in motion. The equipment shall have provisions for proper grounding.

- 6. CONTROLS:** The washing compartments and rinse-extractor compartment shall be equipped with automatic electric timers which operate independently. Neon pilot lights shall be mounted on the control panel to indicate when motors are energized for washing compartments. The rinse-extract pilot light will remain on until the extractor basket stops automatically at completion of cycle.
- 7. DIMENSIONS:** Overall: Length 60 inches (1524 mm); Depth 29-1/2 inches (749 mm); Height 40-1/2 inches (1029 mm); Cubage 104.8 inches (1717 cu cm); Washing Compartment: 18-3/8 inches (467 mm) wide, 17 inches (432 mm) length; Compartment Height 37 inches (940 mm); Weight: Approximately 460 pounds (208.7 kg); Crated for domestic shipment 580 pounds (263 kg); Export shipment 630 pounds (285.8 kg).
- 8. INSTALLATION:** Equipment shall be designed and constructed for installation and operation as follows:
1. Uncrate and place in position. Do not anchor to floor.
 2. The following water supply outlets are required:
 - a. One 3/4 inch (19 mm) cold water outlets for hose connection to washing compartments.
 - b. One 3/4 inch (19 mm) hot water outlets for hose connection to washing compartments.
 - c. One 3/4 inch (19 mm) cold water outlets for hose connection to rinse-extractor compartment.
 3. Attach three heavy duty hoses to 3/4 inch (19 mm) water outlets.
 4. Make one non-rigid drain connections.
 5. Connect machine to electric power supply. **DO NOT USE FUSES**
 6. Read instructions then operate.

Voltage Code	ELECTRICAL RATING ⁴	FLA	BKR	AWG	Sq. mm
A	208-240/60/30 4W	5	15	14	4 x 1.5
C	380-415/50/30 4W	3	15	14	4 x 1.5
D	220-240/50/30 3W	5	15	14	3 x 1.5
F	440-480/60/30 3W	3	15	14	3 x 1.5
G	440/50/30 3W	3	15	14	3 x 1.5
H	380/60/30 3W	3	15	14	3 x 1.5
I	346/50/30 3W	3	15	14	3 x 1.5
J	200/50/30 3W	5	15	14	3 x 1.5
K	200/60/30 3W	5	15	14	3 x 1.5
O	208-240/60/30 3W	5	15	14	3 x 1.5

NOTE: FLA represents full load amp draw. BKR is recommended circuit breaker size as desired. AWG is recommended wire size. Circuit breaker should be 3 pole inverse line type.

Rear View Model UM202 Washer

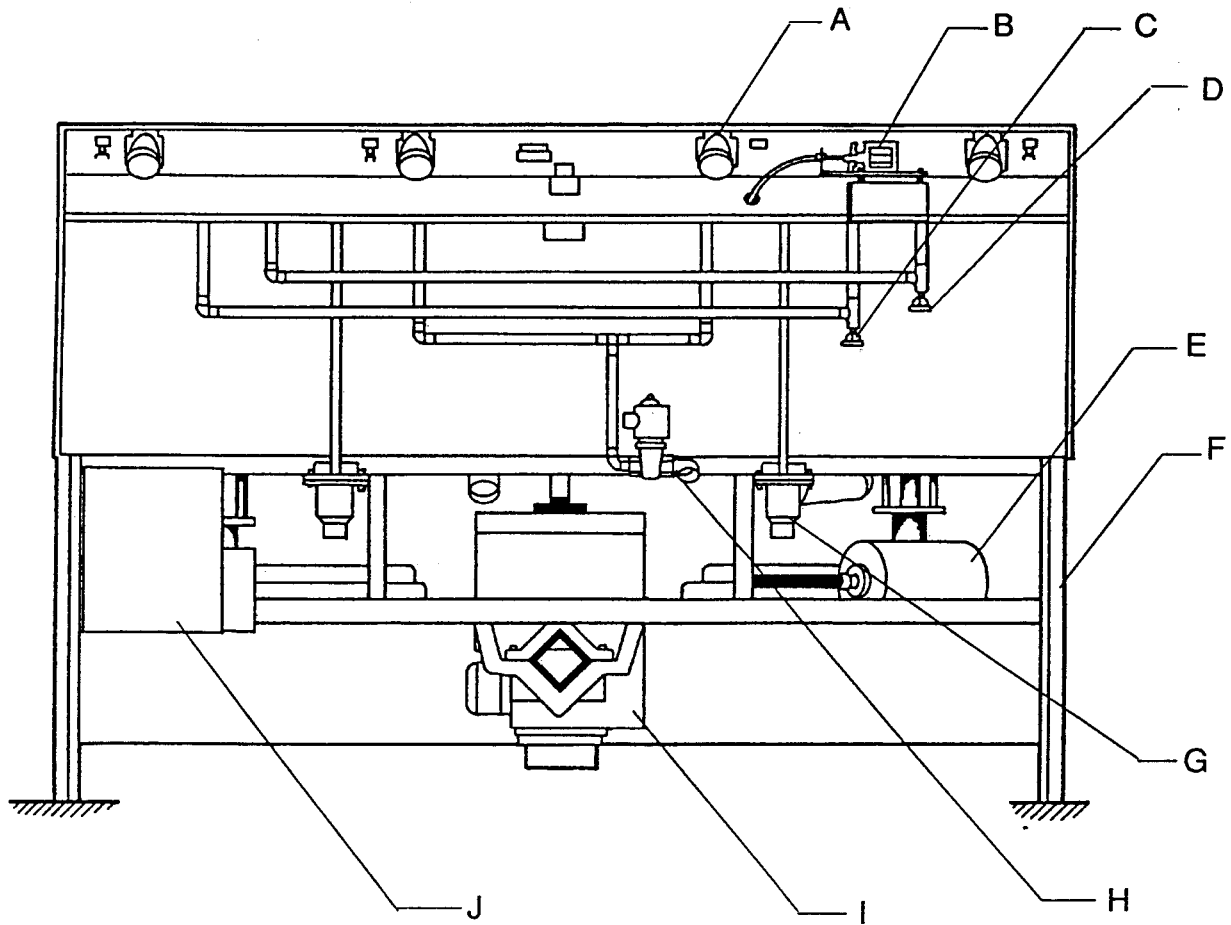

- | | |
|-------------------------------------|-----------------------------------|
| A - Timer | F - Frame |
| B - Lid Lock Solenoid | G - Dump Valve and Drain |
| C - Cold Water Connection | H - Rinse Solenoid and Connection |
| D - Hot Water Connection | I - Extractor Motor |
| E - Agitator Motor and Transmission | J - Electrical Box |

LENGTH: 60 inches (1524 mm)

WIDTH: 29-1/2 inches (750 mm)

OVERALL HEIGHT: 40-1/2 inches (1030 mm)

HEIGHT TO RINSE SOLENOID "H": 18 inches (460 mm)

HEIGHT TO DRAIN: 9 inches (230 mm)

PLUMBING REQUIREMENTS: Use hose furnished for water supply and drain lines. Rigid pipe connections are not recommended. Water supply lines should not be less than 3/4 inch (19 mm).

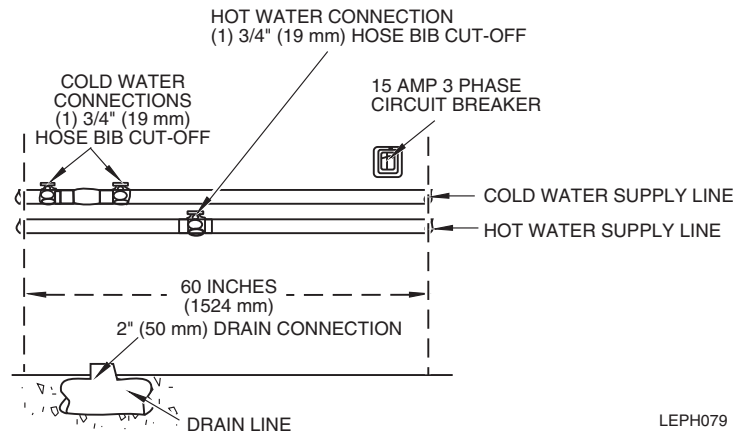

LEPH079

Water and Drain Line Requirements

Number of Washers	Pipe Sizes (Cold or Hot)	Minimum Drain Line
1	3/4 inch (19.05 mm)	2 inches (50.8 mm)
2	1 inch (25.4 mm)	3 inches (76.2 mm)
3	1-1/4 inches (31.75 mm)	4 inches (101.6 mm)
4	1-1/2 inches (38.1 mm)	4 inches (101.6 mm)
5	1-1/2 inches (38.1 mm)	4 inches (101.6 mm)
6	2 inches (50.8 mm)	4 inches (101.6 mm)
7	2 inches (50.8 mm)	6 inches (152.4 mm)
8	2 inches (50.8 mm)	6 inches (152.4 mm)
9	2 inches (50.8 mm)	6 inches (152.4 mm)
10	2 inches (50.8 mm)	6 inches (152.4 mm)

In view of policy of continued improvement, the company reserves the right to change the specifications without notice.